

ARTICLE VI. OFF-STREET PARKING REQUIREMENTS***Sec. 59-581. Scope of regulations.**

The regulations herein set forth shall apply and govern in all zoning districts; provided, however, that in the O-2 and B-5 districts the application of these regulations shall be limited to section 59-585 (use and maintenance of off-street parking spaces), in the B-7 district the application of these regulations shall be limited as set forth in section 59-239, in the MS-1, MS-2 and MS-3 districts the application of these regulations shall be limited as set forth in section 59-277, and in the OD-5 overlay zone district the application of these regulations shall be limited as set forth in section 59-450(c).

(Ord. No. 361-03, § 5, 5-23-03; Ord. No. 660-05, § 10, eff. 9-16-05)

Sec. 59-582. Duty to provide and maintain off-street parking spaces.

(a) The owner(s) and operator(s) of any land area, structure, use by right, or authorized use exception which generates a parking requirement under this chapter shall have joint and several responsibility for providing all parking required by this chapter and maintaining said parking in accordance with the provisions of this chapter.

(b) For land, structures or uses by right actually used, occupied or operated on the effective date of this chapter, the number of existing off-street parking spaces shall not be reduced below the minimum number of spaces required under this article. If such land area, structures or uses by right are enlarged, expanded or changed, there shall be provided the following amounts of off-street parking:

- (1) If such land area, structures or uses by right are enlarged or expanded, there shall be provided for the increment only, at least the amount or number of off-street parking parking spaces that would be required hereunder if the increment were a separate land area, structure or use by right established or placed into operation after the effective date of this chapter; or
- (2) If such land area, structures or uses by right are changed from one (1) use by right to any other use by right allowed under this chapter which requires more off-street parking spaces than the previous use by right, there shall be provided:
 - a. No additional off-street parking spaces if the new use by right parking requirement does not exceed the previous use by right parking requirement by more than twenty-five (25) percent;

***Editor's note**—Ord. No. 361-03, § 5, adopted May 23, 2003, repealed article V, sections 59-581—59-588 in its entirety and reenacted it as article VI, sections 59-588. Former article V pertained to similar material and derived from Code 1950, §§ 614.1—614.8; Ord. No. 671-80, eff. Dec. 19, 1980; Ord. No. 192-82, eff. April 26, 1982; Ord. No. 456-83, eff. Aug. 16, 1983; Ord. No. 392-86, eff. July 8, 1986; Ord. No. 1-88, eff. Jan. 15, 1988; Ord. No. 498-94, eff. July 8, 1994; Ord. No. 631-82, eff. Nov. 19, 1982; Ord. No. 615-86, eff. Sept. 30, 1986; Ord. No. 219-88, eff. April 14, 1988; Ord. No. 322-89, eff. June 26, 1989; Ord. No. 68-97, eff. Feb. 7, 1997; Ord. No. 128-98, eff. March 6, 1998; Ord. No. 618-02, § 28, eff. Aug. 9, 2002.

- b. Additional off-street parking spaces shall be provided for any new use by right as required under this chapter in excess of one hundred twenty-five (125) percent of the overall requirement for the previous use by right.

(c) For all uses by right or authorized use exceptions established or placed into operation after the effective date of this chapter, there shall be provided the amount or number of off-street parking spaces set forth in this article. An off street parking space shall count as a space only if:

- (1) It meets all the requirements of chart 1, off-street parking, located at the end of this article;
- (2) It meets all other requirements of this article and;
- (3) Access to and egress from each such space may be obtained with no more than a standard two movement entrance or exit from said space by a vehicle parking there.

(d) *Parking for disabled persons.* For all uses by right or authorized use exceptions established or placed into operation or expanded after the effective date of the section, there shall be provided the amount or number of off-street parking spaces for disabled persons as follows: for all uses other than multiunit dwellings, the number of such parking spaces shall be two (2) percent of the number of spaces required by section 59-586, "required off-street parking"; provided, however, that at least one (1) such parking space for disabled persons shall be required where twelve (12) or more spaces are required by section 59-586. For multiunit dwellings, off-street parking spaces for disabled persons shall be provided for two (2) percent of the dwelling units or for each dwelling unit occupied by a disabled person, whichever is the greater requirement; provided, however, that at least one (1) such parking space shall be required where twelve (12) or more spaces are required by section 59-586. Dwelling units requiring parking for disabled persons within a multiunit dwelling shall be provided with such spaces at a ratio of one (1) space per dwelling unit and each such parking space for disabled persons shall be a minimum of twelve (12) feet wide and nineteen (19) feet long or an alternative size as suggested by the PUD/PBG rules and regulations. Accessible routes, passenger loading zones and other facilities for disabled persons shall be provided according to the guidelines contained in the PUD/PBG rules and regulations for site plan review.

(e) *Parking for bicycles.* Nonresidential uses having an off-street parking requirement of at least fifteen (15) and not more than forty (40) automobile spaces shall provide a minimum of two (2) off-street bicycle parking spaces. Nonresidential uses having an off-street parking requirement of forty (40) or more automobile spaces shall provide off-street bicycle parking spaces equal to five (5) percent of the total number of automobile off-street parking spaces provided. Subject to review and approval by the transportation office of the entire proposed off-street parking area including but not limited to the design; location; and security features, the total number of required automobile off-street parking spaces may be reduced at the ratio of one (1) automobile off-street parking space for each six (6) bicycle spaces. However, the total

number of required automobile off-street parking spaces shall not be reduced by more than five (5) percent. The director of planning shall adopt rules and regulations establishing the dimensional and equipment standards for bicycle parking areas.

(f) *Parking for historic structures.*

- (1) There shall be no parking requirement for structures designated for preservation or for contributing structures in districts designated for preservation (together "historic structures"), both pursuant to Chapter 30 of the Denver Revised Municipal Code, beyond the number of parking spaces required for the land use and located on site as of August 1, 2007, or for structures designated after August 1, 2007, as of the date of designation.
- (2) Parking spaces required to serve the historic structure that are located off of the property as of August 1, 2007, need not be retained unless the provision of off-site parking spaces is a condition resulting from the quasi-judicial decision of the city council (e.g., as a condition or waiver attached to a rezoning approval).
- (3) Additions to historic structures shall be parked in accordance with this chapter. The parking spaces for an addition to a historic structure are in addition to the number of parking spaces required and located on site as of August 1, 2007. Off street parking requirements for the addition may be met off of the zone lot upon evidence of ownership or a current lease of parking spaces on another zone lot within a 1,500-foot radius of the zone lot containing the historic structure. Divesting ownership or terminating lease of the required parking space shall result in termination of the use permit until the deficiency is remedied.
- (4) In the B-7 zone district, this section shall have no force and effect and subsection 59-239(b) shall govern the parking of historic structures.

(Ord. No. 449, § 5, eff. 8-31-07)

(Ord. No. 361-03, § 5, 5-23-03)

Sec. 59-583. Location of off-street parking space.

Off-street parking spaces shall be located on the same zone lot as the use by right or authorized use exception for which provided, except as set forth in section 59-587.

(Ord. No. 361-03, § 5, 5-23-03)

Sec. 59-584. Combined space.

Parking spaces required by each of two (2) or more uses by right located on the same zone lot need not be separated, and may be used jointly.

(Ord. No. 361-03, § 5, 5-23-03)

Sec. 59-585. Use and maintenance of off-street parking space.

Off-street parking space, including the actual spaces in which vehicles shall be parked as well as all drive aisles and access routes, shall be maintained in accordance with the following specifications:

- (1) Except as allowed by other provisions of this chapter including subsection (2), below, no truck exceeding six thousand (6,000) pounds empty weight, no automobile trailer, bus or motorized recreation vehicle exceeding twenty-two (22) feet in length, and no truck-tractor or semi-trailer shall be stored on any zone lot in a residential district.
- (2) The owner of a school, church or pre-school may apply for a temporary permit to park one (1) or more buses or vans on the property containing the subject use. Such vehicle must be used primarily to transport church members and/or school and pre-school children or students. The zoning administrator shall utilize the procedures of 59-41(b) in processing such a request and shall approve or deny applications for such permits on the basis of the following criteria:
 - a. The number of buses or vans involved is justified by the method of operation and the size of the church, school or preschool.
 - b. The proposed parking area is located away from abutting residential structures and will have a minimal impact on the character of surrounding residential properties.
 - c. If the parking area is located adjacent to residential structures, adequate screening and landscaping will be installed to reduce or eliminate the visual impact of the bus on adjoining residents.

In approving a permit the administrator may attach conditions for the protection of adjoining owners and residents. Approved permits shall expire after a two-year period and may be renewed upon a determination by the administrator that the parking of the bus or van has had no detrimental effect on adjoining residential properties. If there have been any complaints filed about the parking of said bus or van, the procedures of section 59-41(b) shall again be utilized before any renewal is granted. (Ord. No. 459-06, § 15, eff. 7-21-06)

- (3) Shall not be used for the sale, repair, dismantling or servicing of any vehicles, equipment, materials or supplies.
- (4) Shall be graded for proper drainage and provided with an all weather surface of asphalt, asphaltic concrete, concrete, or any equivalent material except that for single-unit dwellings the minimum paving shall consist of an adequate thickness of road base material as determined by the zoning administrator.
- (5) Shall be provided with screening of such dimensions that occupants of adjacent structures are not unreasonably disturbed, either by day or by night, by the movement

of vehicles; except in the B-4, B-5, B-5-T, B-7, B-8, B-8-A, B-8-G, C-MU-10, C-MU-20, C-MU-30, I-0, I-1, and I-2 districts, no cleaning or maintenance of parking lots utilizing motorized equipment may be performed between 11:00 p.m. and 6:30 a.m. each day.

(Ord. No. 439-07, § 21, eff. 8-20-07)

- (6) Shall be provided with entrances and exits so located as to minimize traffic congestion.
- (7) Shall be provided with wheel guards or bumper guards so located that no part of parked vehicles will extend beyond the property line.
- (8) Loudspeaker systems shall not be used.
- (9) Shall have not more than one (1) attendant shelter building which shall conform to all setback requirements for structures in the district and which shelter building in the RS-4, R-0, R-1, R-2, R-2-A, R-2-B, R-3, R-3-X, R-4, R-5, B-A-1, B-A-2, H-1-A, H-1-B and H-2 districts shall contain not more than fifty (50) square feet of gross floor area.

(Ord. No. 895-03, § 61, eff. 12-2-03)

- (10) Off-street bicycle parking spaces shall be a minimum of two (2) feet wide and six (6) feet long. Access aisles running perpendicular to the length of the parking spaces shall be a minimum of five (5) feet in width or three (3) feet in width when running parallel to the length of the parking space. Each parking space shall be located within a secured area or shall include a metal anchor which will secure the frame and both wheels in conjunction with an integral key, coin-operated lock, user supplied lock or similar device.

- (11) Landscape plan.

- a. A landscape plan must be submitted to, and approved by, the planning office prior to the issuance of the zoning permit required by section 59-26 of the Revised Municipal Code.
- b. The landscape plan shall meet the requirements of the rules and regulations adopted by the planning board, following a public hearing before the board; provided, however, that no rule or regulation shall be adopted without the prior approval of the chief of police or his designee. The aforementioned rules and regulations shall make adequate provision for, but shall not necessarily be limited to, the following requirements:
 1. Perimeter boundary landscaping or screening;
 2. Street frontage landscaped planting strips;
 3. Internal parking area landscaping; provided, however, that there shall not be internal landscaping requirements for parking areas with twenty (20) or fewer parking spaces, and that the internal landscaping requirements for parking areas with one hundred (100) or fewer spaces shall be limited to those portions of parking areas that have double loaded rows of parking spaces; and provided, however, that there shall not be internal landscaping requirements for parking lots in the B-5, OD-2/B-5, OD-3/B-5, OD-4/B-5, B-5-T, OD-2/B-5-T, or OD-4/B-5-T districts that occupy less than twenty-five

thousand (25,000) square feet of gross area unless such parking lots are adjacent to existing parking lots and the combined area of the two (2) or more adjacent parking lots is more than twenty-five thousand (25,000) square feet;

(Ord. No. 439-07, § 22, eff. 8-20-07)

4. Parking row lengths;
 5. Standards relating to plant material fences;
 6. Planter boxes and walls (materials and heights), visual barriers, walkways, irrigation, maintenance, and lighting;
 7. Landscape plan review procedure including; permits required; improvement guarantees; submittal requirements and other pertinent information.
- c. The intent of the rules and regulations promulgated hereunder shall be to improve the appearance of off-street parking areas, to protect the appearance and value of the surrounding properties and neighborhoods, to protect the users of parking areas, to improve environmental conditions and thereby promote the general welfare. This is to be achieved by providing for the installation and maintenance of landscaping and lighting for screening, aesthetic qualities, and security.
- d. Applicability of the rules and regulations.
1. The rules and regulations shall apply to off-street parking areas that require a zoning permit as provided by section 59-26(1); provided, however, that use-by-right parking areas in the B-7 or B-8 zones shall be landscaped according to special requirements for use-by-right parking areas contained in the rules and regulations.
 2. Notwithstanding the requirement of subsection 59-585(11)d.1. above, the following shall be excluded:
 - i. Parking areas containing fewer than fifteen (15) parking spaces calculated on the basis of three hundred (300) square feet per space;
 - ii. Parking garages and structures.
- e. No rule or regulation shall be promulgated under the authority of this section 59-585(11) which establishes a solid visual barrier in excess of three (3) feet in height; provided, however, any landscaping requirement or rule or regulation may be modified on a case by case basis with the approval of the chief of police or his designee.
- f. The rules and regulations, as adopted by the planning board, shall be based upon studies made by either planning staff or independent landscape architects establishing costs of construction and planting. In adopting the rules and regulations, the planning board shall review the cost information provided by the planning staff and/or the independent landscape architect as well as public

testimony, and on the basis of this information, establish requirements that are deemed to be reasonable. The planning board shall adopt any amendment to the rules and regulations in the same manner as set forth above.

(Ord. No. 361-03, § 5, 5-23-03)

Sec. 59-586. Required off-street parking.

Except where reductions in parking are otherwise specifically provided in this chapter, at least the amounts of off-street parking space required by this article VI shall be provided. All off-street parking spaces required under this chapter shall be designed in accordance with the dimensions set out in chart no. 1, off-street parking, (following section 59-588). The following parking classes shall apply to all uses by right or authorized use exceptions. If for any reason the classification of any such use cannot be determined for the purpose of establishing the amount or number of off-street parking spaces to be provided, the parking class of such use shall be fixed by the zoning administrator. Upon compliance with the provisions of article IV (affordable housing), chapter 27 (housing), of the Denver Revised Municipal Code, a twenty (20) percent reduction in the total number of required parking spaces shall be granted.

(Ord. No. 459-06, § 16, eff. 7-21-06; Ord. No. 655-06, § 2, eff. 10-13-06)

- (1) *Parking class one*, being composed of all uses by right which are enumerated in the schedule hereinafter provided:
 - a. There shall be one and one-half (1½) off-street parking spaces provided for each dwelling unit in a multiple unit dwelling; provided, however, that for a multiple unit dwelling located in a B-4, R-4-X or B-8-G district there shall be provided one (1) off-street parking space for each dwelling unit; and provided, further, that for a multiple unit dwelling whose occupancy is restricted entirely to individuals sixty (60) years or more of age, there shall be provided one (1) off-street parking space for each three (3) dwelling units.
 - b. There shall be one (1) off-street parking space provided for each three (3) dwelling units and/or rental rooms in a residence for older adults.
 - c. There shall be three-quarters (.75) of a space provided per unit in an assisted living facility provided that the zoning administrator may increase or decrease the required amount by up to one-half (.5) space per unit subject to the administrative review and public notice procedures in section 59-41. The zoning administrator may approve such increase or reduction only upon finding that the assisted living facility generates less or more parking need or demand due to the specific nature and character of the facility, its occupants, and/or visitors. If a reduction is permitted under this provision, no additional parking reduction otherwise available under this chapter will be granted. Any person, or the city, may apply for an increase or decrease from the base requirement upon an application for a use permit for such a facility.

(Ord. No. 57-09, § 18, eff. 1-30-09)

- (2) *Parking class two*, being composed of all uses by right and authorized use exceptions which are enumerated in the schedule hereinafter provided: There shall be one (1) off-street parking space provided for each six hundred (600) square feet of gross floor

area contained in any structure or structures containing any use by right; provided, however, that for each habitable unit in a motel there need be provided not more than one (1) off-street parking space and further provided that for nursing home, hospice uses requests for up to a 50 percent reduction of parking spaces may be made to the zoning administrator subject to the administrative review and public notice procedures in section 59-41. The zoning administrator may approve such reduction only upon finding that the nursing home/hospice generates less parking need or demand due to the specific nature and character of the facility, its occupants, and/or visitors. If a reduction is permitted under this provision, no additional parking reduction otherwise available under this chapter will be granted.

(Ord. No. 20-07, § 3, eff. 1-26-07)

- (3) *Parking class three*, being composed of all uses by which are enumerated in the schedule hereinafter provided: Parking shall be provided in an amount equal to one-fourth ($\frac{1}{4}$) of the area of the zone lot on which the use by right is located; provided, however, a community recreational facility or tennis club which restricts its membership to persons living in a specific geographical area shall provide at least ten (10) percent of the area of its zone lot for off-street parking; and provided further, however, an aquaculture facility shall provide one (1) off-street parking space for each employee on the largest shift.
- (4) *Parking class four*, being composed of all uses by right which are enumerated in the schedule hereinafter provided: There shall be one (1) off-street parking space provided for each two hundred (200) square feet of gross floor area contained in any structure containing a use by right.
- (5) *Parking class five*, being composed of all uses by right which are enumerated in the schedule hereinafter provided: An area equal to one-fourth ($\frac{1}{4}$) the gross floor area in all structures containing the use by right.
- (6) *Parking class six*, being composed of all uses right which are enumerated in the schedule hereinafter provided: There shall be a parking area equal to one-tenth the gross floor area in all structures containing the use by right; provided, however, that one (1) additional parking space shall be provided for each artist studio containing a dwelling unit.
- (7) *Parking class seven*, being composed of all uses by right which are enumerated in the schedule hereinafter provided:
 - a. Each elementary or grade school or junior high school shall provide ten (10) off-street parking spaces plus one (1) off-street parking space for each classroom;
 - b. Each senior high school shall provide one (1) off-street parking space for each teacher and employee plus one (1) off-street parking space for each six (6) students based on design capacity for such senior high school;

- c. Any school not an elementary or grade school, junior high school or senior high school shall provide an area equal to one-half (1/2) the gross floor area occupied by the use by right in a structure or structures.
 - d. Senior centers located in a church or school in an R-2 district need provide no off-street parking area beyond that which is or was provided by the church or school.
- (8) *Parking class eight*, being composed of all uses by right which are enumerated in the schedule hereinafter provided: There shall be one (1) off-street parking space provided for each three hundred (300) square feet of gross floor area contained in any structure.
- (9) *Parking class nine*, being composed of all uses by right which are enumerated in the schedule hereinafter provided: There shall be one (1) off-street parking space provided for each five hundred (500) square feet of gross floor area contained in any structure.
- (10) *Parking class 10*, being composed of all eating places with drive-through facilities: There shall be one (1) off-street parking space provided for each two hundred (200) square feet of enclosed floor area set aside as an eating area, plus one (1) off-street parking space for each three hundred (300) remaining square feet of enclosed floor area in the structure. Spaces for vehicles that are in the drive through facility shall count towards the parking requirement, except that such spaces shall not count for more than fifty (50) percent of the required parking.
(Ord. No. 326-06, § 13, eff. 5-26-03)
- (Ord. No. 361-03, § 5, 5-23-03)

Sec. 59-587. Special plan for location of off-street parking space.

(a) *Purpose of procedure.* Under the standard provisions of this article, off-street parking space is required to be located on the same zone lot as the use by right for which the space is provided. Pursuant to the procedure hereinafter set forth, either part or all of required off-street parking space may be located off the zone lot of the use by right for which the space is provided.

(b) *Locations of space.* Off-street parking space under this special plan need not be located on the same zone lot as the use by right for which the space is provided, but may be located on a separate zone lot; provided, however:

- (1) That the separate zone lot on which the off-street parking space is located shall abut the zone lot on which the use by right is located; provided, however, that a street or alley shall not destroy abutment; provided, further, that if the zone lot on which the use by right is located abuts a fixed rail transit system, the off-street parking space may be separated by no more than two hundred (200) feet from the zone lot on which the use by right is located if the site plan for the separate off-street parking space is approved by the department of zoning administration; and

- (2) That separated off-street parking space shall be located only in zoning districts where the parking of vehicles is an enumerated use by right and shall be used only for the provision of separated off-street parking space.

(c) *Applications for approval, how made and contents.* All applications for approval of a special plan hereunder shall be filed with the department of zoning administration by the owners of the entire land area to be included within the special plan, and the owners of all structures then existing on such land area; shall contain sufficient evidence to establish to the satisfaction of the department that the applicants are the owners of the designated land and structures; shall contain such information and representations required by this article or deemed necessary by the department and shall include plans showing the following details:

- (1) The location of the uses by right or structures for which off-street parking space is required.
- (2) The location of off-street parking spaces.
- (3) A landscape plan as required by section 59-585(11).

(d) *Review of application for approval.* All applications hereunder shall be reviewed by the department of zoning administration and either approved or disapproved. Any approval hereunder may establish necessary conditions and limitations.

(e) *Approved plan registered and recorded.* Upon approval of a special plan hereunder, a copy of such plan shall be registered among the records of the department of zoning administration and a copy of such plan, or such other record thereof as deemed proper by the department shall be recorded by the department in the office of the city clerk.

(f) *Effect of registered and recorded special plan.* All special plans registered and recorded hereunder shall be binding upon the applicants for such special plans, their successors and assigns, shall limit and control the issuance and validity of all zoning permits and zoning certificates and shall restrict and limit the use and operation of all land and structures included within such special plans to all conditions and limitations specified in such plans and the approvals thereof.

(g) *Amendment of registered and recorded special plans.* All special plans registered and recorded hereunder may be amended pursuant to the same procedure and subject to the same limitations and requirements by which such plans were approved, registered and recorded.

(h) *Withdrawal of registered and recorded special plans.* Upon application to the department of zoning administration by the owners of the entire land area included within any special plan registered and recorded hereunder, and the owners of any structures then existing thereon any such plan may be withdrawn, either partially or completely, from registration and released from recording if all uses, land and structures remaining under such plan can be made to comply with all conditions and limitations of the plan and all uses by right, land and structures withdrawn from such plan can be made to comply with all regulations established

by this article and unrelated to any special plan. Upon approval of an application hereunder, the department of zoning administration shall register among its records and record in the office of the city clerk an appropriate certificate of such withdrawal.

(Ord. No. 361-03, § 5, 5-23-03)

Sec. 59-588. Off-street parking classes.

Double asterisks following a use by right indicate special requirements contained in section 59-586.

(a) *Class one:*

- (1) Assisted living facility;
- (2) Dwelling, multiple unit;
- (3) Residence for older adults.

(Ord. No. 57-09, § 19, eff. 1-30-09)

(b) *Class two:*

- (1) Bed and breakfast;
- (2) Child care center;
- (3) Historic structures use exception; office, art gallery;
- (4) Hospital (not animal);
- (5) Hotel;
- (6) Library;
- (7) Motel;
- (8) Museums, other special purpose cultural institutions;
- (9) Nursing home, hospice;
- (10) Residence for consuls or clergy, monastery, convent, similar institution of religious training;
- (11) Studio, professional;
- (12) University or college.

(c) *Class three:*

- (1) Aquaculture facility;
- (2) Church, religious institution;
- (3) Community or senior center or recreational facility;
- (4) Recreation services, outdoor.

(d) *Class four:*

- (1) Adult establishment;
- (2) Automobile wash, laundry and/or polishing shop;

- (3) Body art establishment;
- (4) Bookstore;

- (5) Brewpub;
(Ord. No. 909-05, § 8, eff. 12-16-05)
 - (6) Conference center, meeting hall;
 - (7) Eating place;
 - (8) Food sales or market, large;
 - (9) Food sales or market, small;
 - (10) Garden supply store;
 - (11) Home building materials and supplies, sales or rental;
 - (12) Liquor store;
 - (13) Mortuary;
 - (14) Pawn shop;
 - (15) Recreation services, indoor;
 - (16) Retail, service, repair, consumer, large scale;
 - (17) Retail, service, repair, consumer, medium scale;
 - (18) Retail, service, repair, consumer, small scale;
 - (19) Retail, service, repair, consumer, special;
 - (20) Theatre, indoor.
- (e) *Class five:*
- (1) Communications service;
 - (2) Contractors, special trade, general;
 - (3) Fire station;
 - (4) Junkyard;
 - (5) Laboratory, research, development, technological service;
 - (6) Railroad facilities;
 - (7) Recycling center, facility;
 - (8) Recycling collection station;
 - (9) Service, repair, commercial;
 - (10) Sports and/or entertainment facility;
 - (11) Terminal freight, air courier services;
 - (12) Terminal, public transportation, local;
 - (13) Terminal and service facility for bus system;
 - (14) Utility, major impact;
 - (15) Utility, minor impact;
 - (16) Vehicle storage, commercial;

(Ord. No. 449, § 6, eff. 8-31-07)

(f) *Class six:*

- (1) Artist studio;
 - (2) Assembly, without fabrication;
 - (3) Contractors, special trade, heavy, contractor yard;
 - (4) Food preparation and sales, commercial;
 - (5) Manufacturing, fabrication, and assembly, custom;
 - (6) Manufacturing, fabrication, and assembly, general;
 - (7) Manufacturing, fabrication, and assembly heavy;
 - (8) Manufacturing, fabrication, and assembly, light;
 - (9) Printing service, publishing, business support;
 - (10) Wholesale trade light, storage of nontoxic, nonhazardous materials;
 - (11) Wholesale trade general, storage of toxic and/or hazardous materials.
- (Ord. No. 449, § 6, eff. 8-31-07)

(g) *Class seven:*

- (1) School, vocational or professional;
- (2) School, elementary, secondary.

(h) *Class eight:*

- (1) Ambulance service;
- (2) Animal care, kennel cattery;
- (3) Animal sales, service, care, household pets only;
- (4) Auto gasoline filling station, emissions inspection;
- (5) Auto pawn lot, auctioneer for automobiles, large vehicles or heavy equipment;
- (6) Automobile, motorcycle, light truck sales, leasing, rental;
- (7) Automobile repair garage;
- (8) Bank and financial services;
- (9) Club or lodge;
- (10) Nursery, plant;
- (11) Police station;
- (12) Postal facility, neighborhood;
- (13) Rooming and/or boarding house;
- (14) Vehicle, equipment sales, leasing, service, rental.

(i) *Class nine:*

- (1) Clinic, dental or medical;
- (2) Furniture furnishings, retail sale, large scale;
- (3) Office, non-dental, non-medical.

(j) *Class ten:*

- (1) Eating place, drive through.
(Ord. No. 20-07, § 4, eff. 1-26-07)

CHART 1. OFF-STREET PARKING

For other than 90-degree parking, the minimum aisle width for two-way traffic shall be twenty (20) feet.

If a public alley is used as the aisle or access to adjoining parking spaces, the spaces or projection must be lengthened as necessary to provide a total alley or aisle width of twenty (20) feet for 0-degree through 75-degree angle parking and twenty-three (23) feet for 90-degree angle parking. This requirement shall apply to all new uses and developments except single unit dwellings and duplexes.

Parking angles between 0 and 30 degrees or between 75 and 90 degrees are not allowed. Other angles between 30 and 75 degrees are allowed and the dimensions for those angles shall be determined through interpolation.

Off-Street Parking

Part A: Parking Lot Dimensions—Universal Sized Stall (8.5 feet × 17.5 feet)

<i>Parking Angle</i>	<i>Stall Length</i>	<i>Stall Width</i>	<i>Projection</i>	<i>Aisle</i>	<i>Module</i>	<i>Interlock Reduction</i>	<i>Overhang Allowance</i>
	(A)	(B)	(C)	(D)	(E)	(F)	(G)
0°	22'	8.5'	8.5'	10.0'	27.0'	—	—
30°	17.5'	8.5'	15.0'	11.0'	41.0'	2.0'	1.5'
45°	17.5'	8.5'	17.0'	13.0'	47.0'	2.0'	2.0'
60°	17.5'	8.5'	18.0'	16.0'	52.0'	1.5'	2.0'
75°	17.5'	8.5'	18.5'	18.0'	55.0'	1.0'	2.5'
90°	17.5'	8.5'	17.5'	23.0'	58.0'	—	2.5'

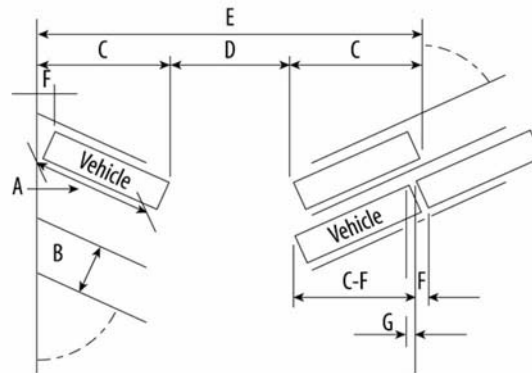

PART B: Parking Lot Dimensions
Separately Designated Small Car (SC), 7.5' X 15.5', Stalls

Part B: Parking Lot Dimensions: Separately Designated Small Car (SC), 7.5 feet x 15.5 feet, Stalls

The dimensions from this chart shall be used only in controlled situations as approved by the zoning administrator. Such approval shall only be given where the owner/manager is able to: limit parking to employees or residents; determine which employee or resident, and what type of vehicle shall be allowed to park in specific parking spaces, and can enforce such restrictions.

Small car stalls shall not exceed forty (40) percent of the total stalls provided.

<i>Parking Angle</i>	<i>Stall Type</i>	<i>Stall Length (A)</i>	<i>Stall Width (B)</i>	<i>Vehicle Projection (C)</i>	<i>Aisle (D)</i>	<i>Typical Module (E)</i>	<i>Inter-lock Reduction (F)</i>	<i>Over-hang (G)</i>
0°	SC	18.0	7.5'	7.0'	10.0'	24.0'	—	2.0'
30°	SC	15.5'	7.5'	14.0'	11.0'	39.0'	1.8'	1.3'
45°	SC	15.5'	7.5'	15.2'	12.0'	42.4'	1.5'	1.5'
60°	SC	15.5'	7.5'	16.3'	13.5'	46.1'	1.3'	1.7'
75°	SC	15.5'	7.5'	16.5'	17.3'	50.3'	0.8'	1.8'

(Ord. No. 361-03, § 5, 5-23-03)

Secs. 59-589—59-595. Reserved.